

CAR (VW BUG)

By: Charles Esseltine (2001) Edited by: Jeremy Shafer (2002)

I know that it is not an exact likeness. But so many people have called this a Bug, that I have bowed to their will.

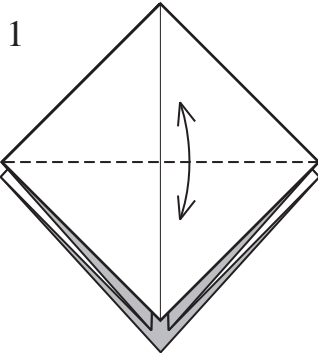

Begin with a preliminary base white side out for a white car, with colored wheels. I think foil is best for this model. But it can be done from any material. Fold and unfold the top layer.

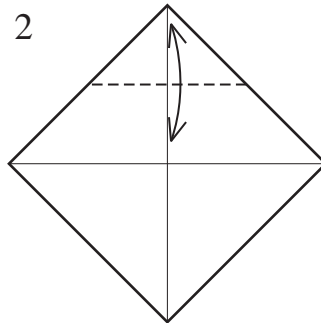

Fold the top to meet the center. Then unfold.

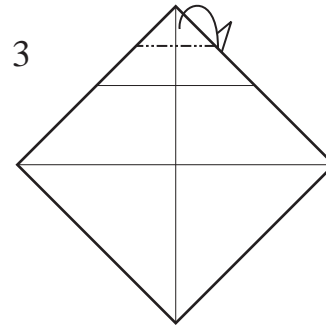

Fold the top point behind to the nearest crease.

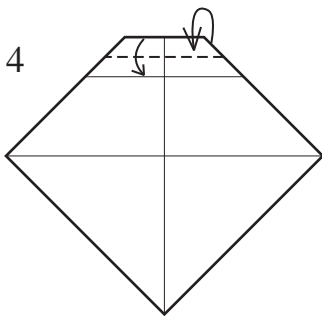

Fold down the new edge. This brings the top point back to the front.

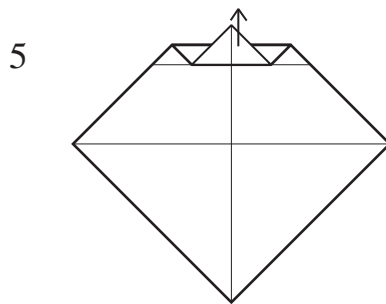

Unfold the layers.

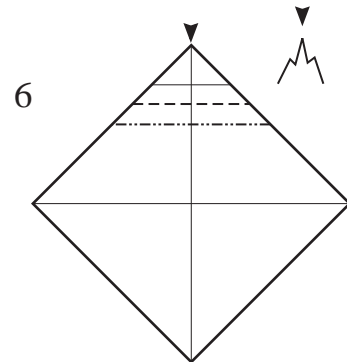

Pleat sink the center, with the center pointing up. Partially opening the model is necessary.

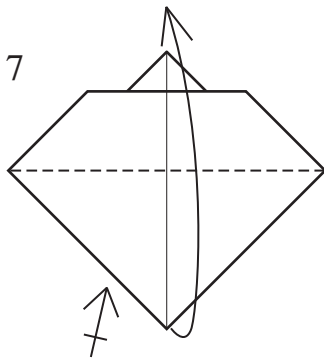

Fold up the front flap. Repeat behind.

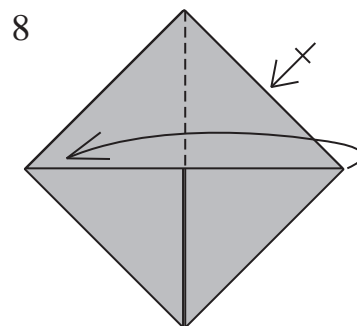

Open up the side, and refold the model so that the white side is on the outside.

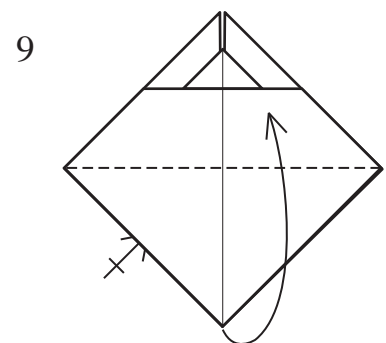

Fold up the remaining sides.

10a

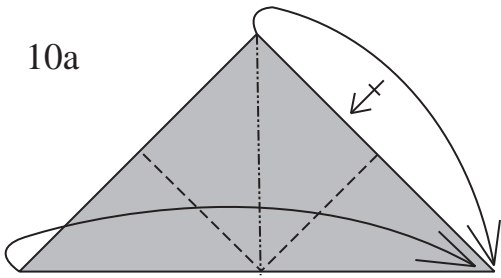

On the front layer, fold the top point to the right corner. Then fold the left point to the right corner.

10b

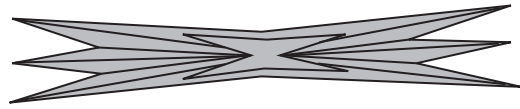

This is how the bottom will look like when it's done.

11

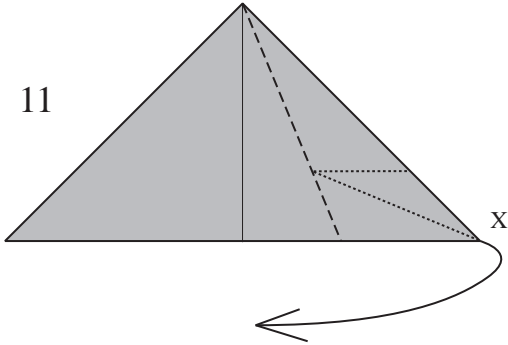

Fold the top 3 layers to the centerline. This will pull up one layer from point X. Fold it down to meet the bottom line.

12

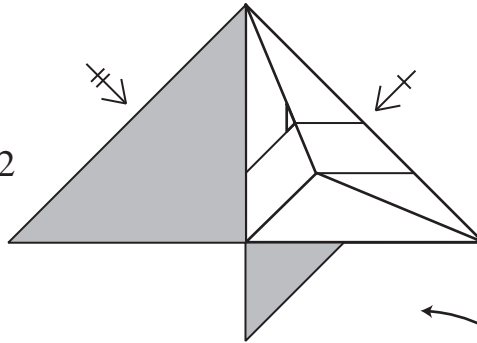

This is how it will look. Repeat on the other three sides.

14

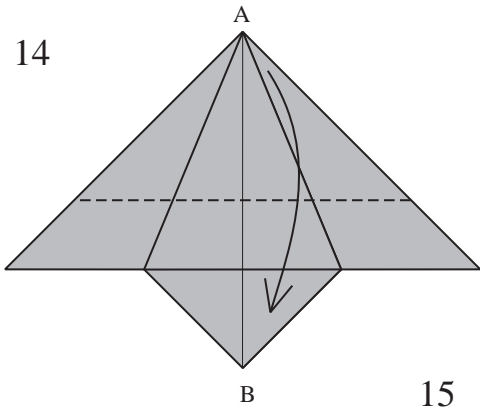

Fold the first layer down from point A to point B.

13

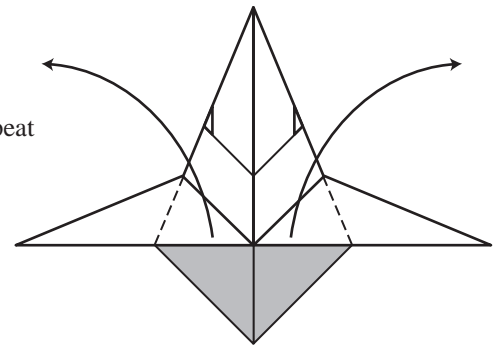

Open out the two middle sections without unfolding the ends.

15

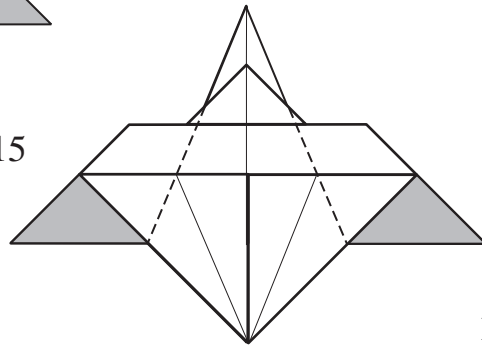

Fold the sections back along the existing lines.

16

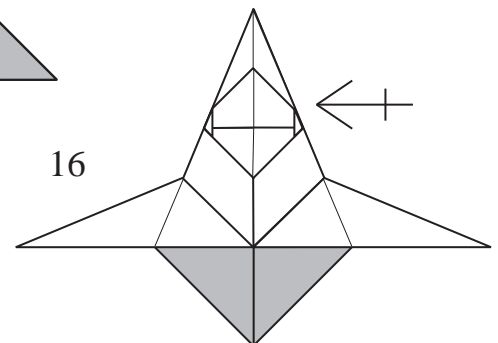

Repeat steps 13-15 on the back.

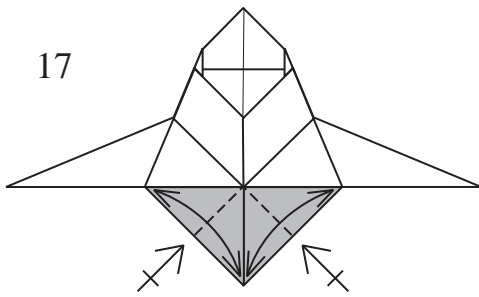

17

Fold and unfold the bottom flaps on both sides.

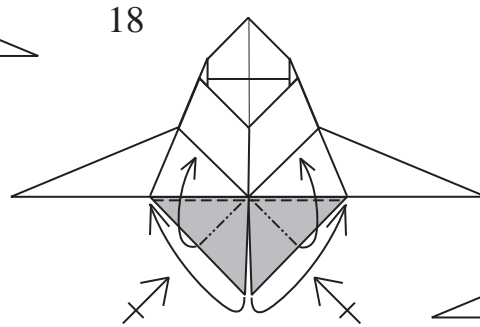

18

Squash fold the bottom sections. Repeat behind.

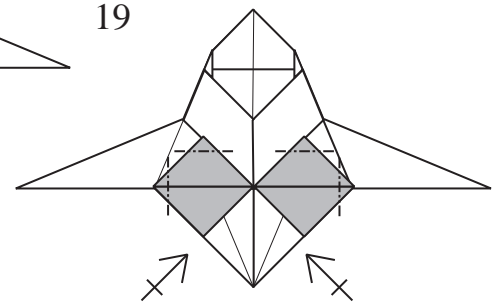

19

Fold in the points on the outside and top of the wheels. Repeat behind.

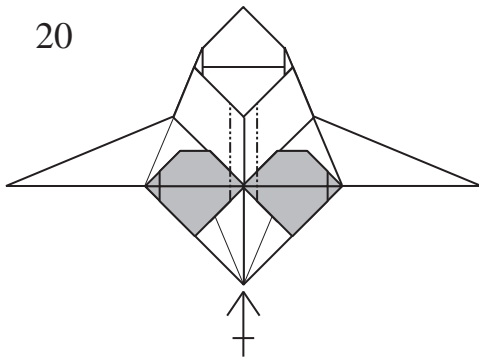

20

Fold the edges inward the same distance as in step 19. These are parallel to the centerline. Repeat Behind.

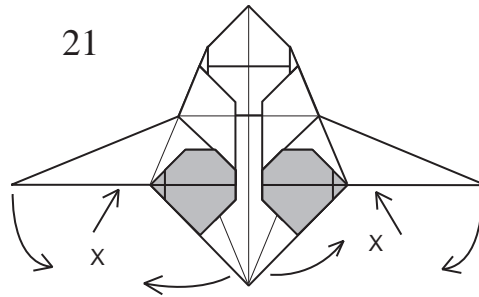

21

Open the bottom and form the roof. At point (X) open the layers and push upward on the interior layer to form the hood and trunk. Pull down the left and right points.

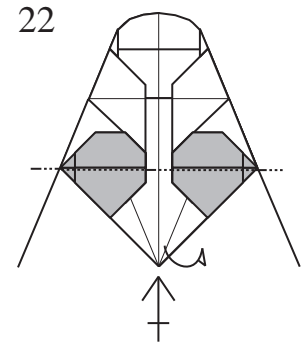

22

Fold the layers behind the wheels, inside the model.

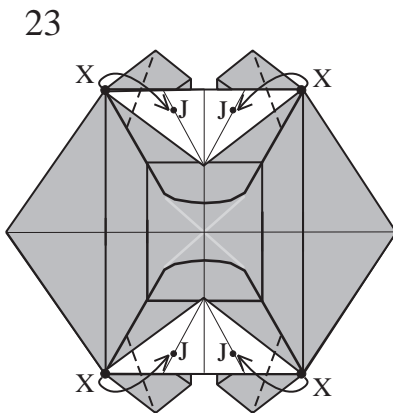

23

Looking inside the model, fold the inner layer from the points marked (X) to the points marked (J). [Thanks to my friend Joe Power for locating point (J).]

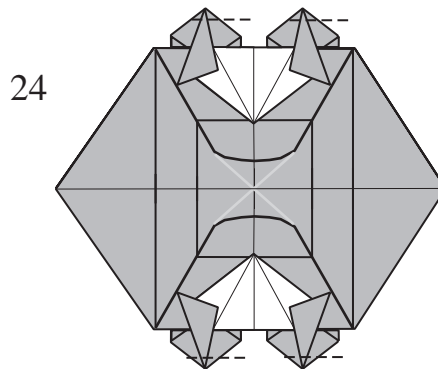

24

Fold in the bottoms of the wheels. Note: The larger the model, the more you can round the wheels.

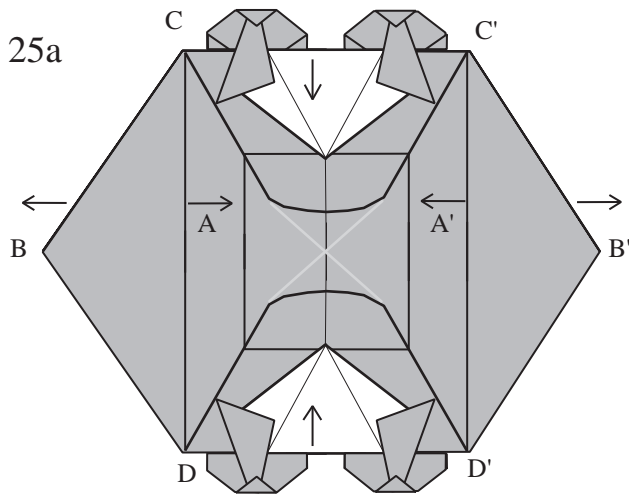

25a.) On each side pull only layer (A & A') in towards the center. Line CD of layer (A) will arc inward, and the sides (CC' & DD') will move towards each other. The outer points (B & B') will move apart.

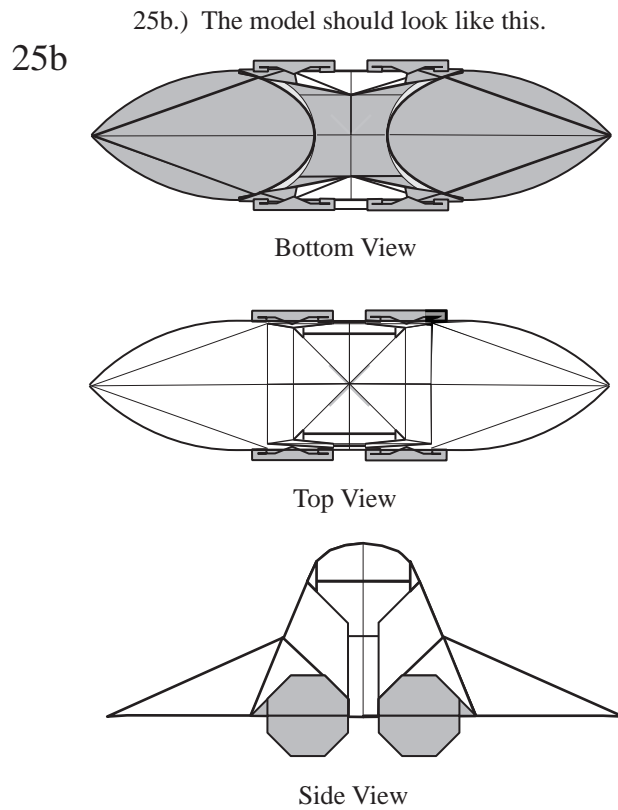

Now for the tough part! Choosing which side will be the front!

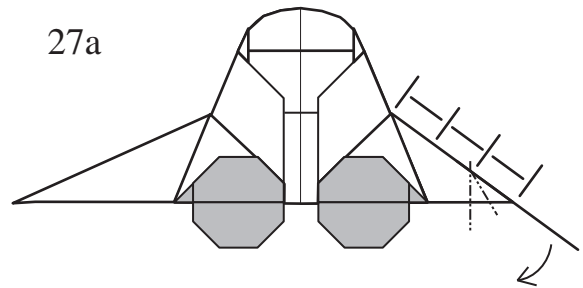
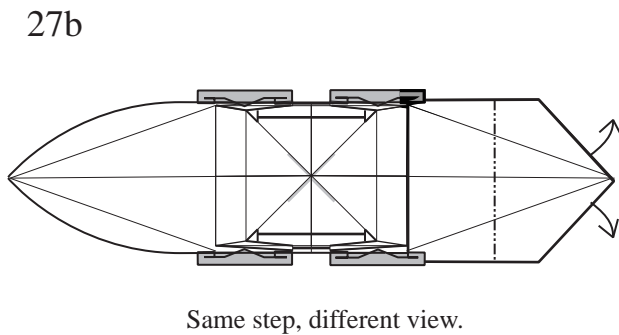
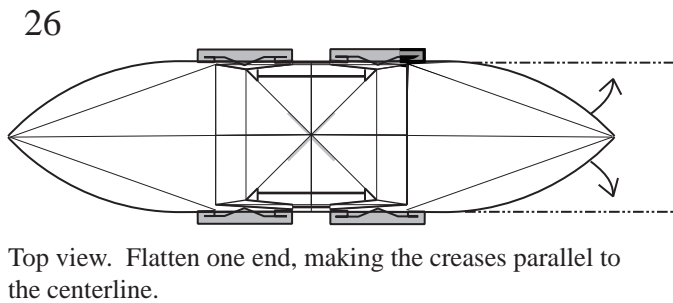

This looks harder than it is. About 2/3 of the way down the edge of the hood, make a soft crease. Pinch the corners so that the front points straight down.

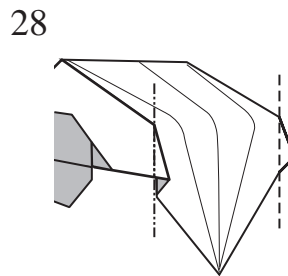

Fold the tips inward, so that they are flat against the front.

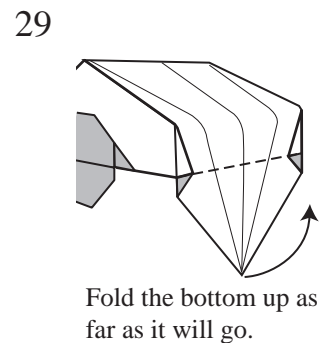

Fold the bottom up as far as it will go.

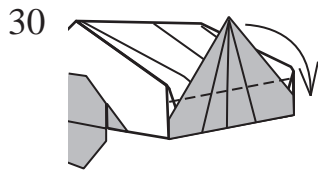

Now fold it down a little bit shy of the top of the hood.

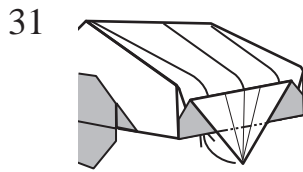

To finish the headlights, just tuck the remaining tip under the edge.

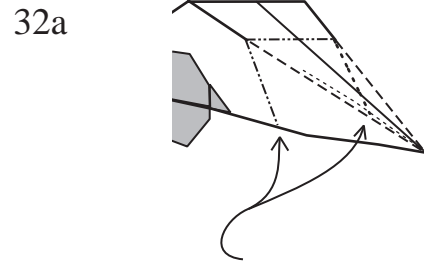

Now for the trunk, and license plate. Make an arbitrary fold parallel to the back windshield's edge. (Note: The Beetle has a round back, so make this fold as close as possible to the windshield.) And reverse the creases as indicated. A soft crease will form on each side of the trunk.

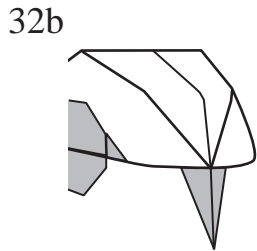

This will be the result. You'll know if its right if the bottom edge is straight across. These two points will meet in the middle of the back. If you want a wider European style plate, leave a gap between the points.

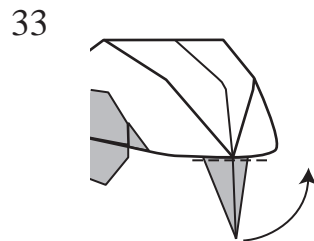

From the bottom edge, fold the point up as far as it will go.

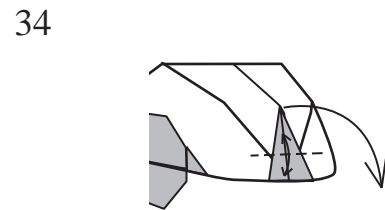

Using the edges as a guide, fold, and unfold a line where they meet. Bring the point back down.

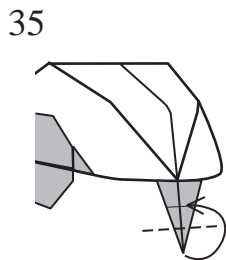

Fold the tip to the marker fold.

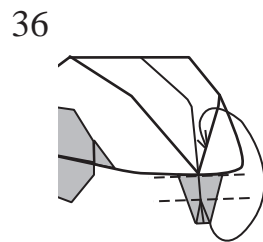

Tuck the flap inside the edges to lock the trunk.

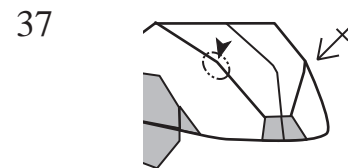

Now that the trunk is formed, we can add the taillights. Dimple sink the points to taste.

O.K. We've got the trunk locked. Now We've got to figure out how to unlock the doors!

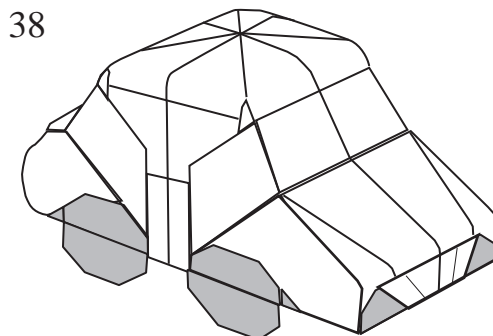

The rear end is done.

And so is the car!

Drive Safely!

