

# EGYPTIAN SLIT-FACED BAT

A  
F  
B  
1  
2  
99

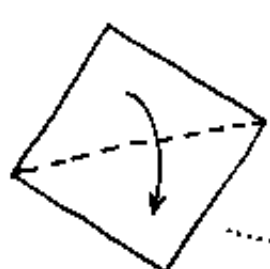

① WSH.

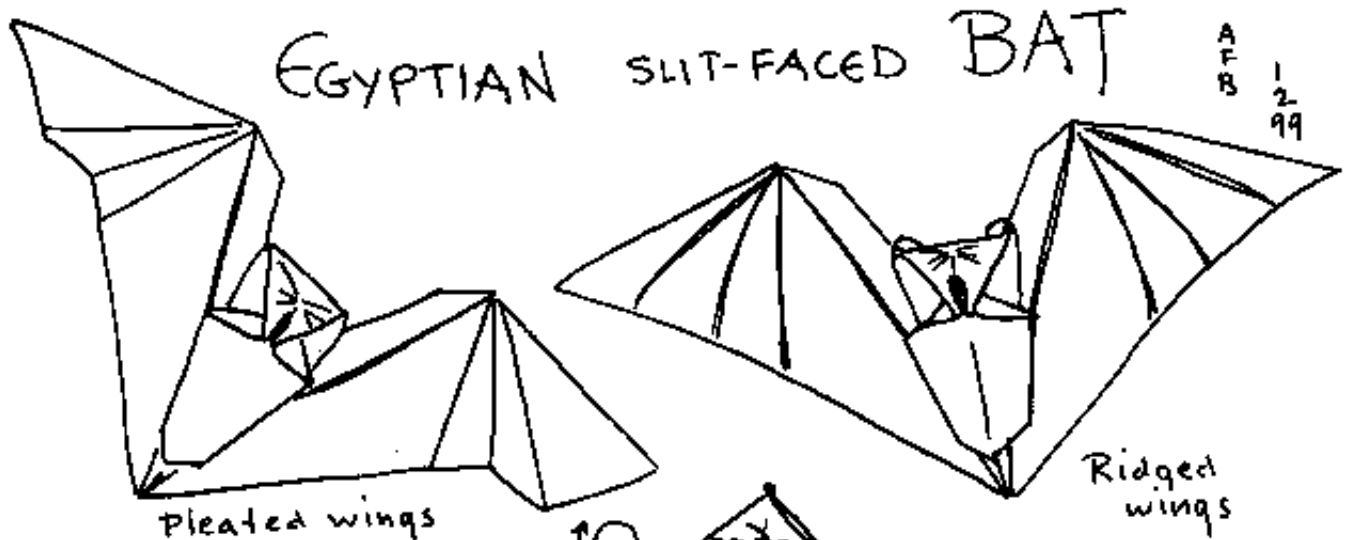

②



③ VF down,  
④ 3/4 from top.

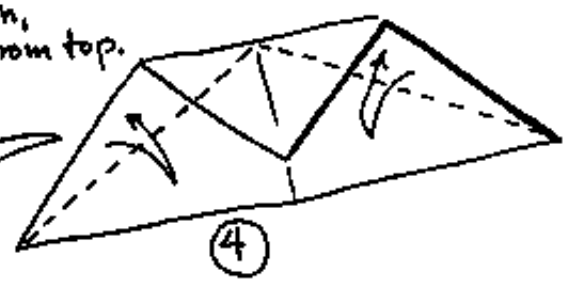

④

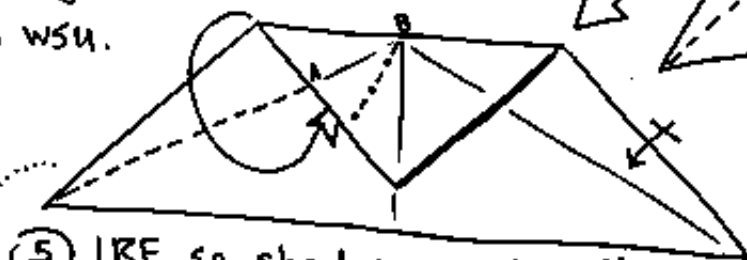

⑤ IRF so short crease AB aligns with middle vertical. Repeat.

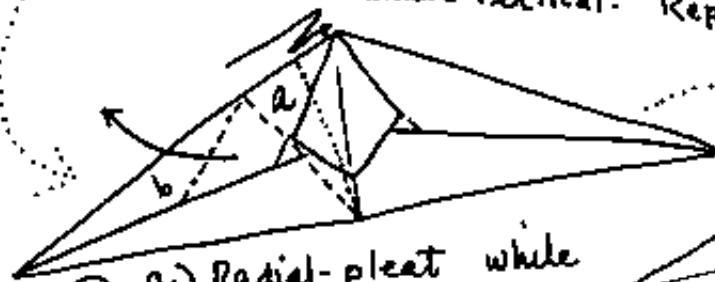

⑥ a) Radial-pleat while  
b) lifting paper.

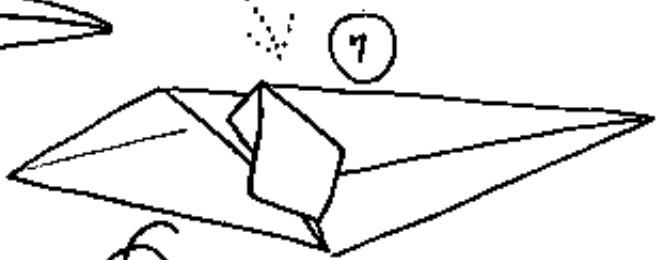

⑦

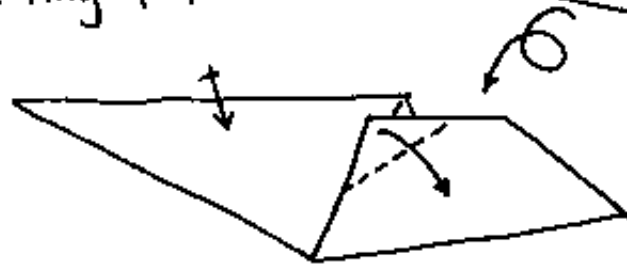

⑧ VF, then repeat 6-8 on other half.

# Egyptian slit-faced BAT, p.2

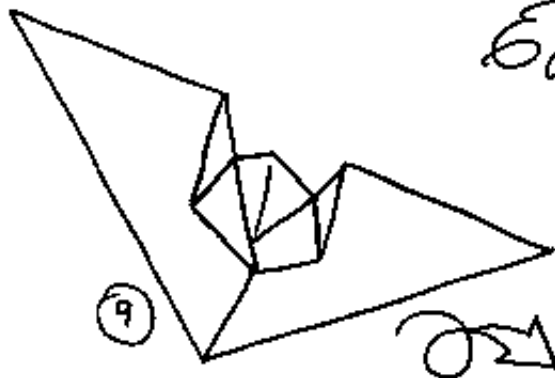

- 10 a) Rabbit-ear near layer & pull peak down.  
b) Narrow body.

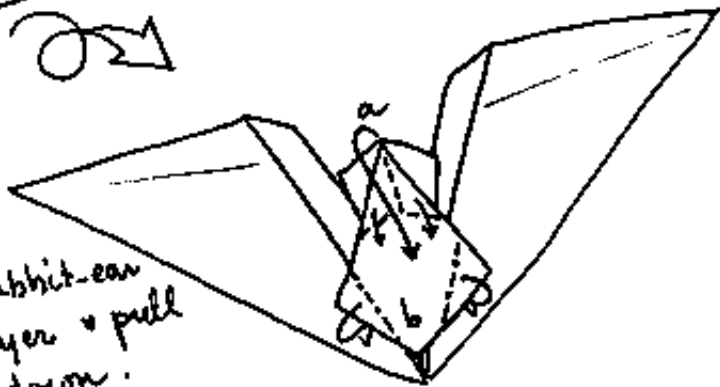

- 11 a) Pinch up 3 sharp ridges (not merely Mt. folds) on each wing.

OR

- b) Radial-pleat 3 folds (right-angled VF first) on each wing.

