

TURKEY

Duo-color paper in charcoal black and pale pink would best suit this model, but I've never seen any. The legs, head, beak & throat show the underside of a square of kami. A $9\frac{1}{2}$ " square yields a $4\frac{1}{2}$ " tall turkey. Start with a preliminary fold, body color out.

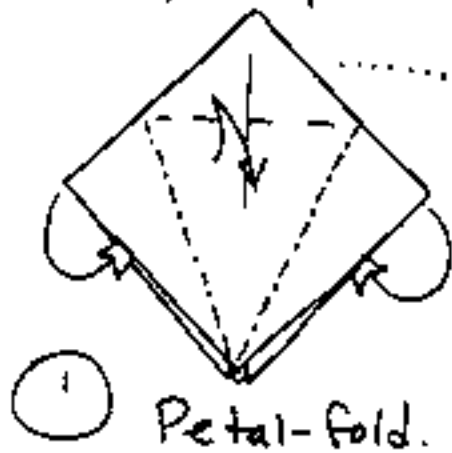

A
F
B
||
-
99



① Petal-fold.

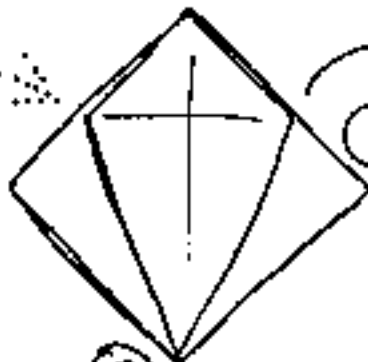

② Flip model over.

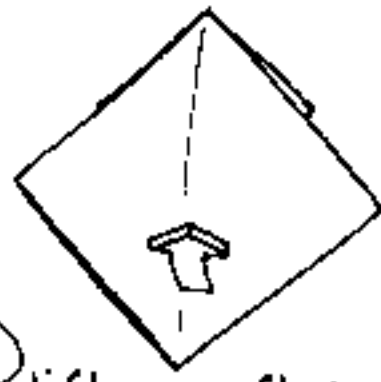

③ Lift near flap.

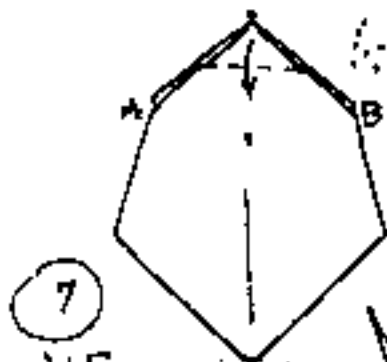

④ VF as if for step 1, but only layer shown.



⑤ Line up existing small crease with new folded edge and flatten.

⑦ VF peak to a point below AB. Tilt model.

⑥ Repeat 3-5 on right.

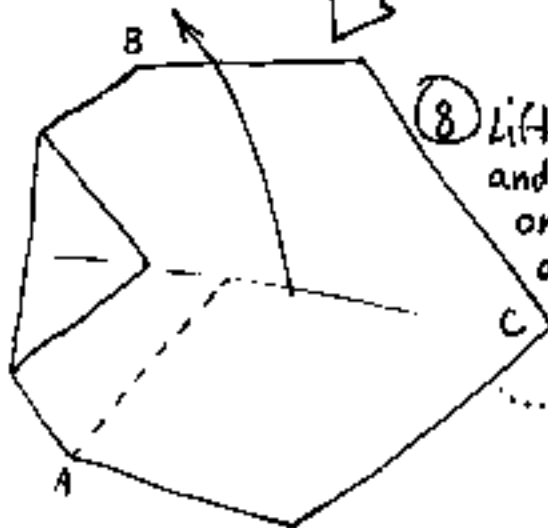

⑧ Lift wide flap C and crease only as far as shown.

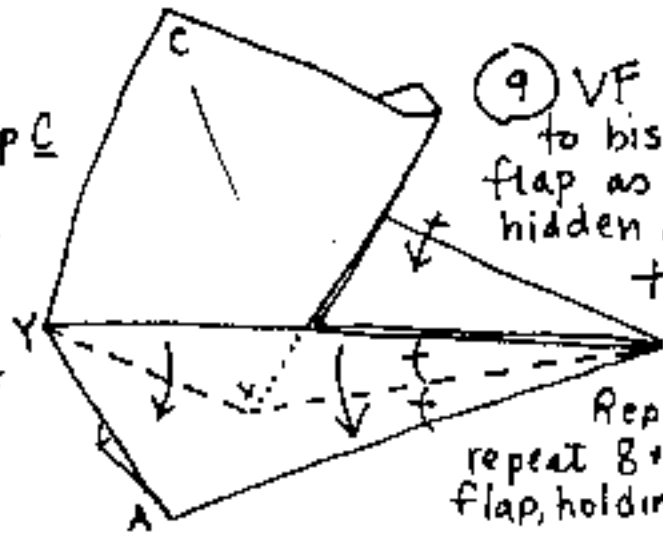

⑨ VF near layer to bisect long flap as far as hidden edge X, then out to corner Y. Replace C & repeat 8+9 on opposite flap, holding C to left.

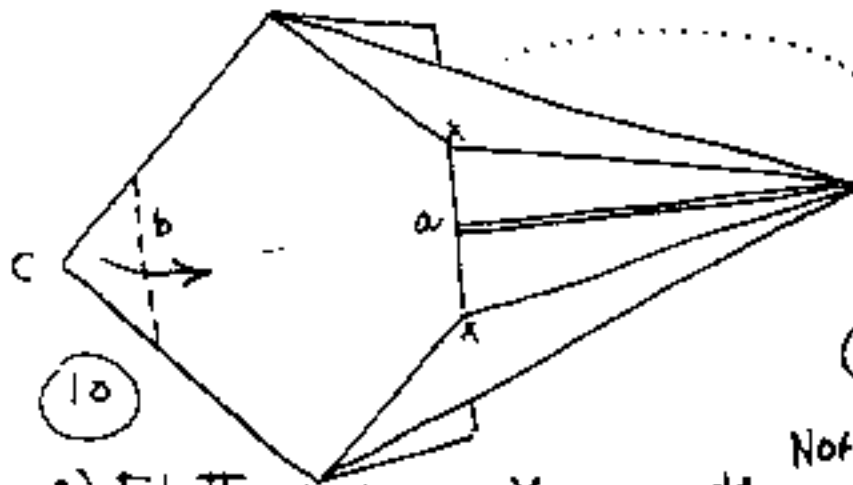

10

- a) Flatten between Xs.
- b) VF corner C.

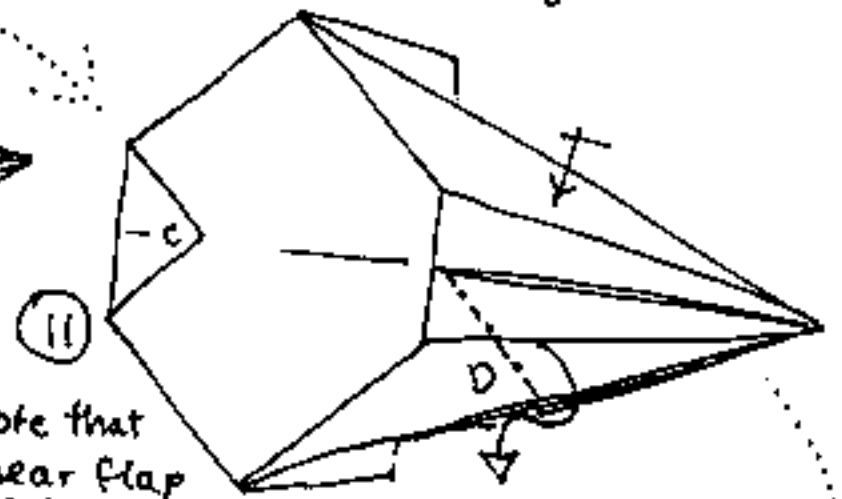

11

Note that the near flap D (leg) has 3 edges. 1 RF between this flap's two far edges. Repeat opp.

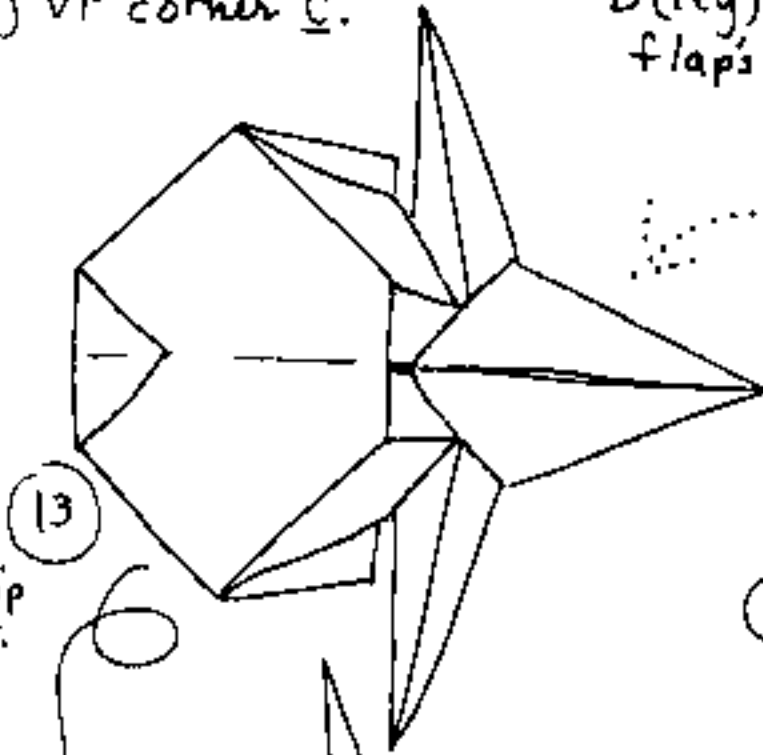

13

Flip over.

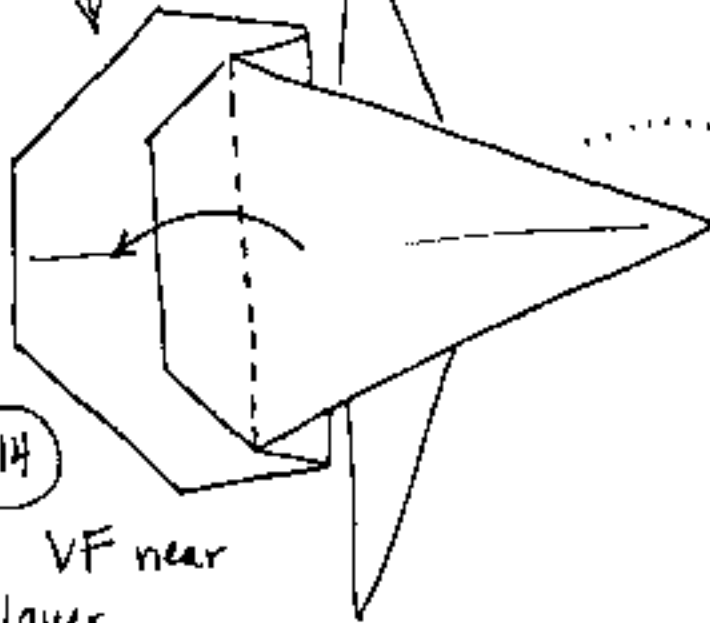

14

VF near layer.

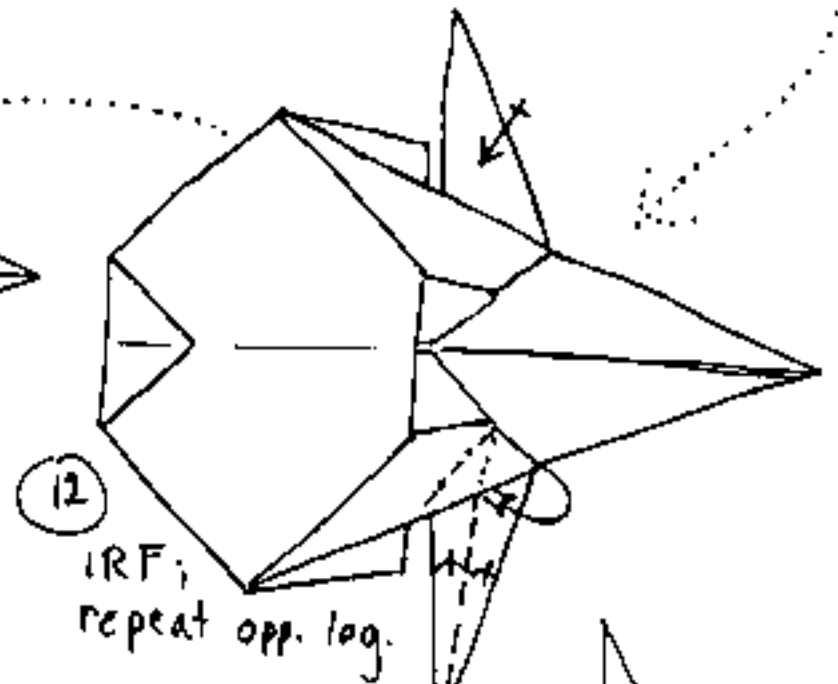

12

1 RF; repeat opp. leg.

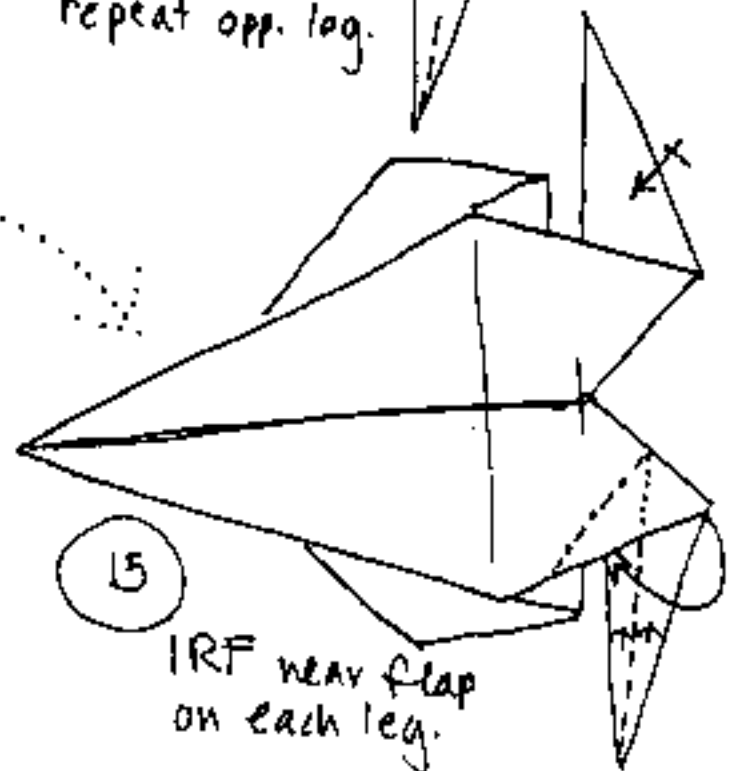

15

1 RF near flap on each leg.

Turkey, p. 3

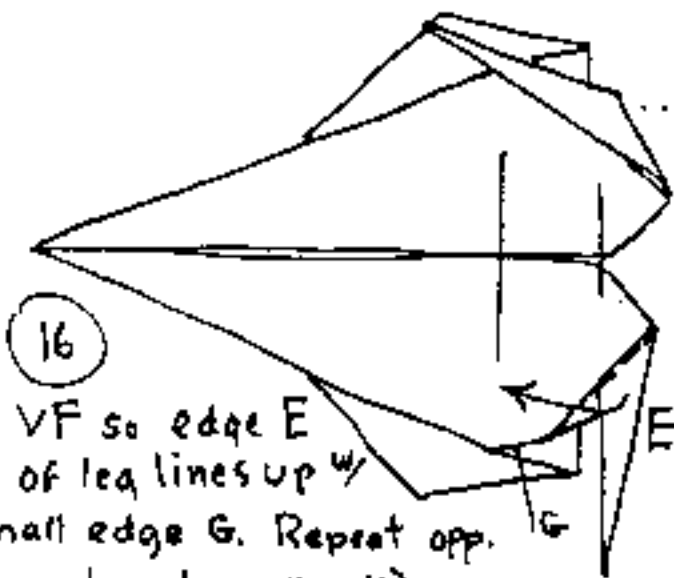

16
VF so edge E
of leg lines up w/
small edge G. Repeat opp.
(Upper leg shows result).
Unfold and ORF on creases.

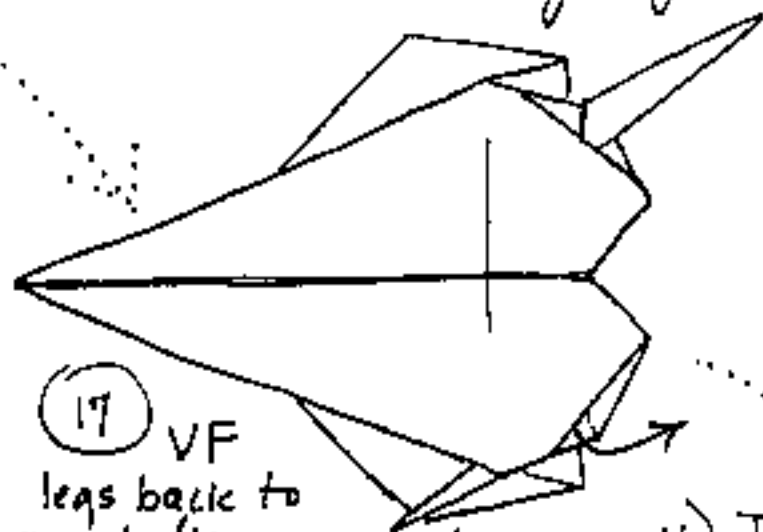

17 VF
legs back to
right (Upper one shows result). Then
ORF on the pre-crease so both
surfaces of leg show inner color.

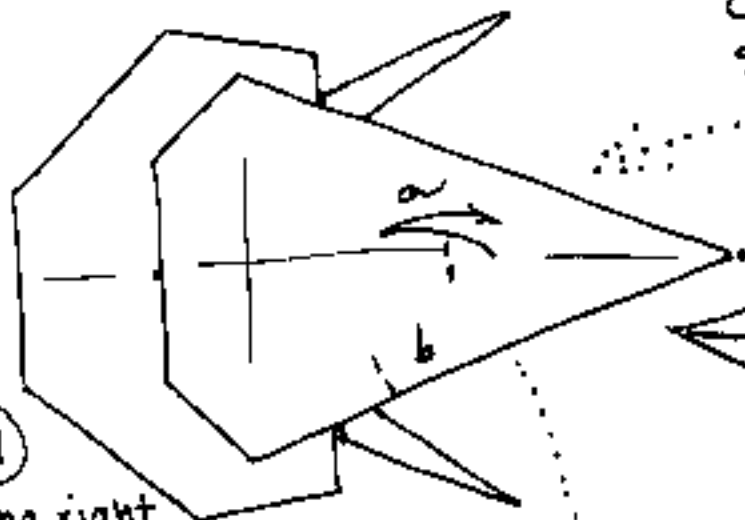

19
a) Bring right
tip to folded edge + pinch.
b) Pinch lower edge just to
right of leg.

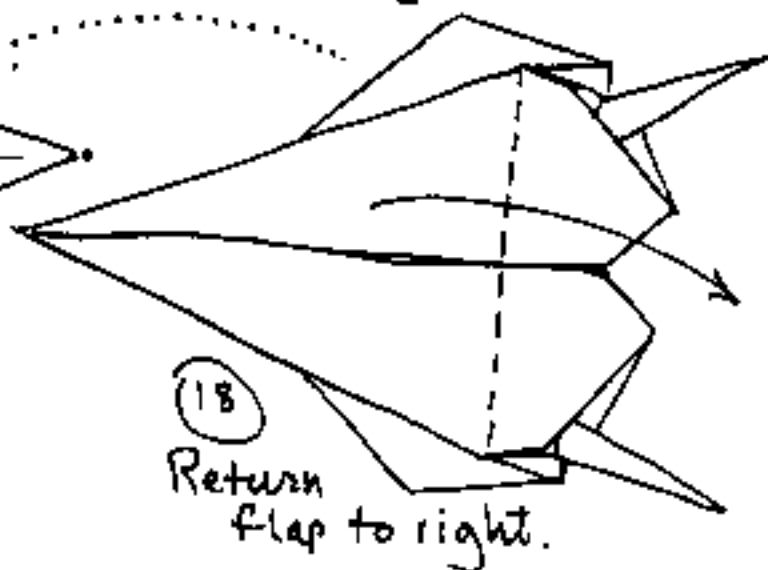

18
Return
flap to right.

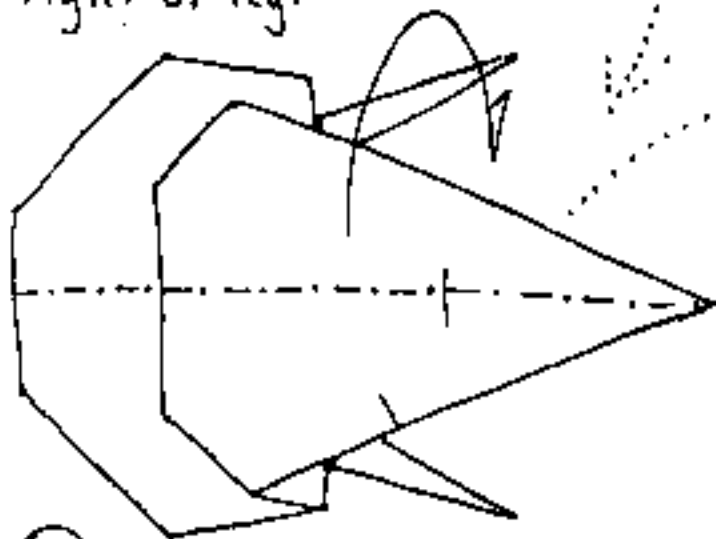

20
MF model in half.



21
ORF between pinches.

Turkey, p. 4

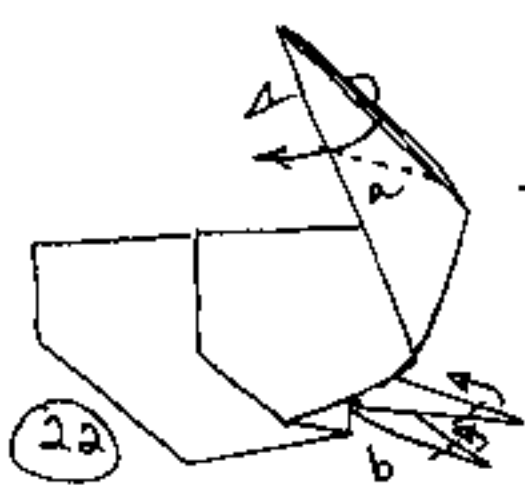

22

Note 3 edges in front.
 a) Pre-crease, then carefully, without tearing, ORF between layers on far side.
 b) IRF feet so inner color shows on each near surface.

enlarged detail

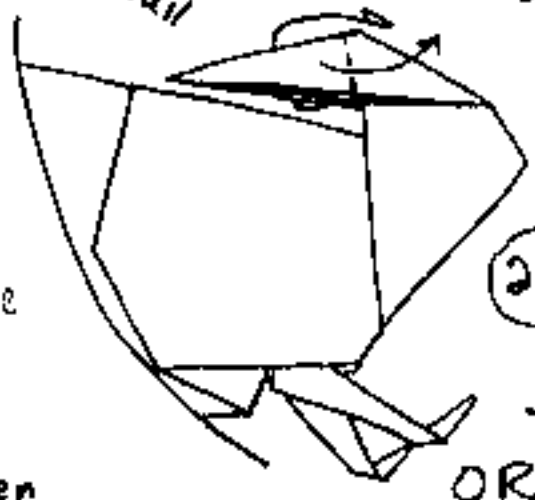

23

Pre-crease, ^{w/ hinge fold} then carefully, ORF between the layers on the near side

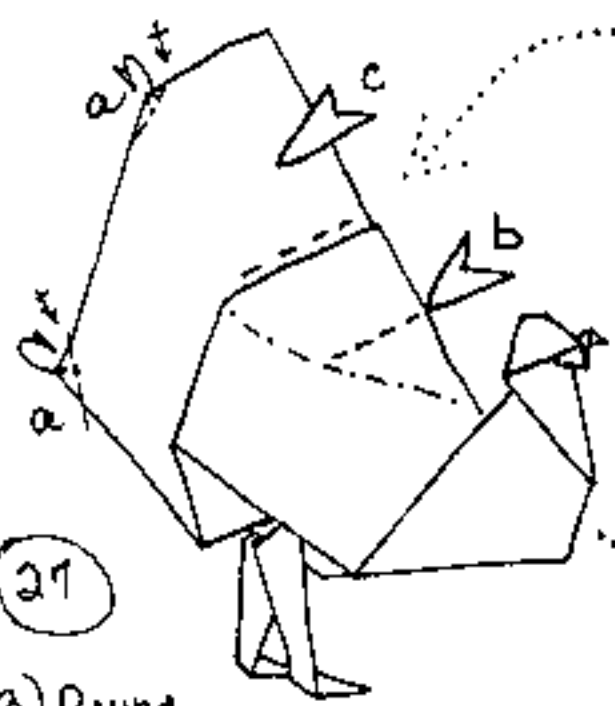

27

a) Round edge of tail with 4 small IRFS.
 b) Push in to make body 3-D, pinching folds lightly.
 c) Push in + bring edge of tail upright.



26 IRF



25 IRF

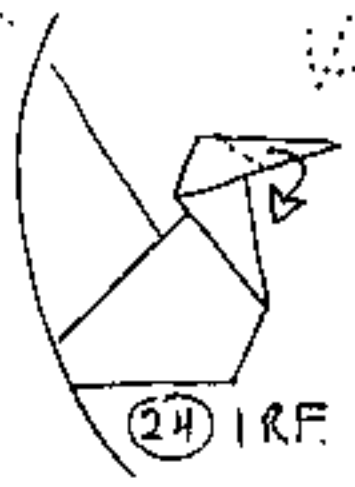

24 IRF

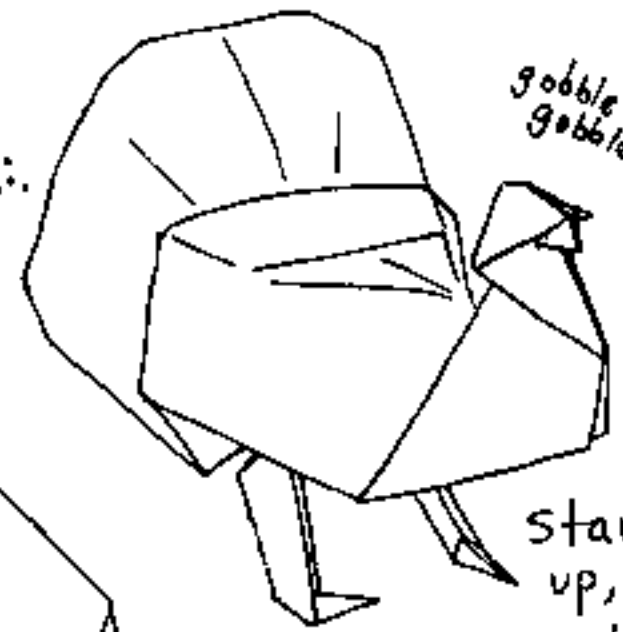

28

Stand model up, adjusting feet as nec.

To use turkey on a greeting card, ignore 27 b+c. Glue flat model to card.

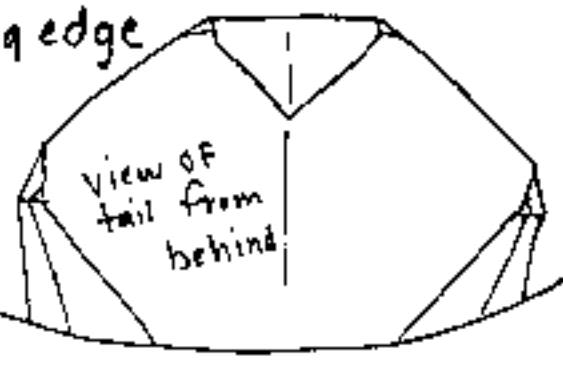

view of tail from behind

TURKEY

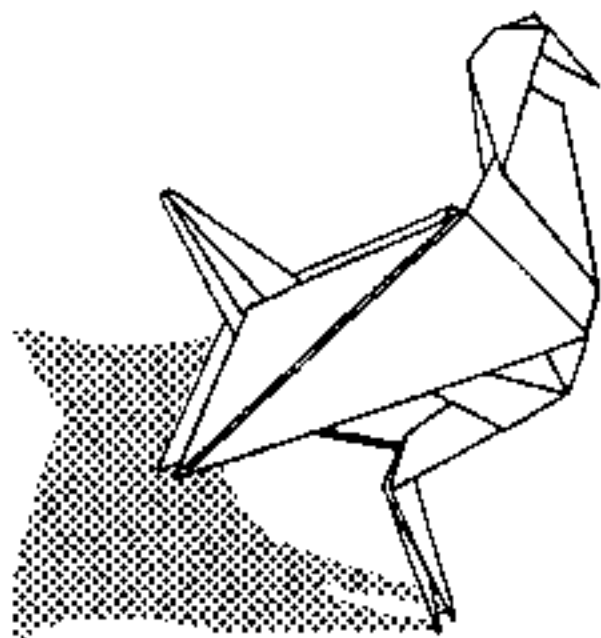

by GEORGE RHOADES
from "Secrets of Origami"
by Robert Harbin

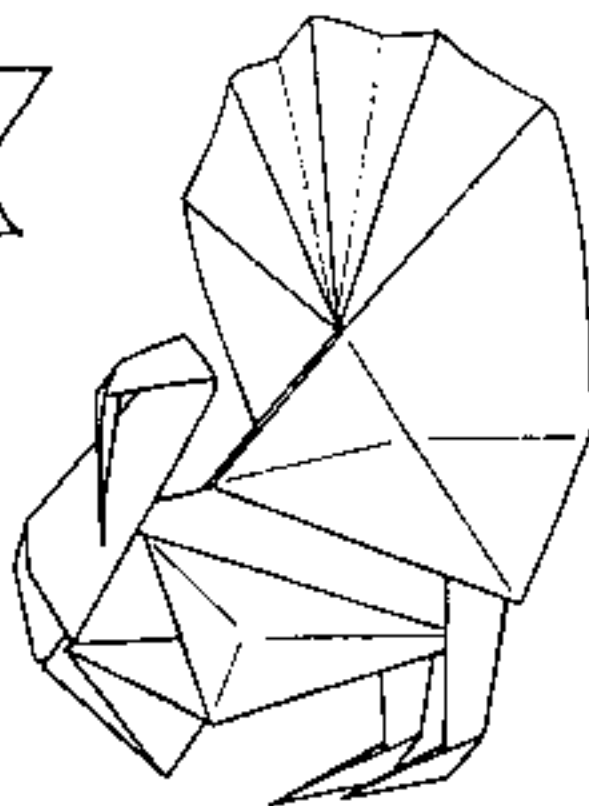

by FRED ROHM
from "Best of Origami"
by Samuel Randlett



by ROBERT HARBIN
from "Paper Magic"

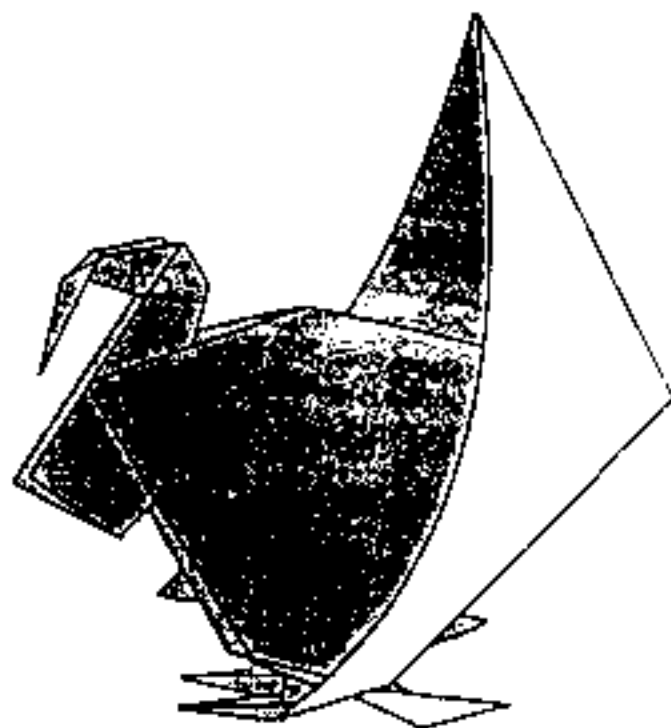

by ISAO HONDA
from "World of
Origami"